

THIS DRAWING IS UNPUBLISHED. RELEASED FOR PUBLICATION

© COPYRIGHT

REVISIONS						
P	F	ZONE	LTR	DESCRIPTION	DATE	APPROVED
✓	✓	Z1		REVISED PER ECO-11-005294	05APR11	HMR

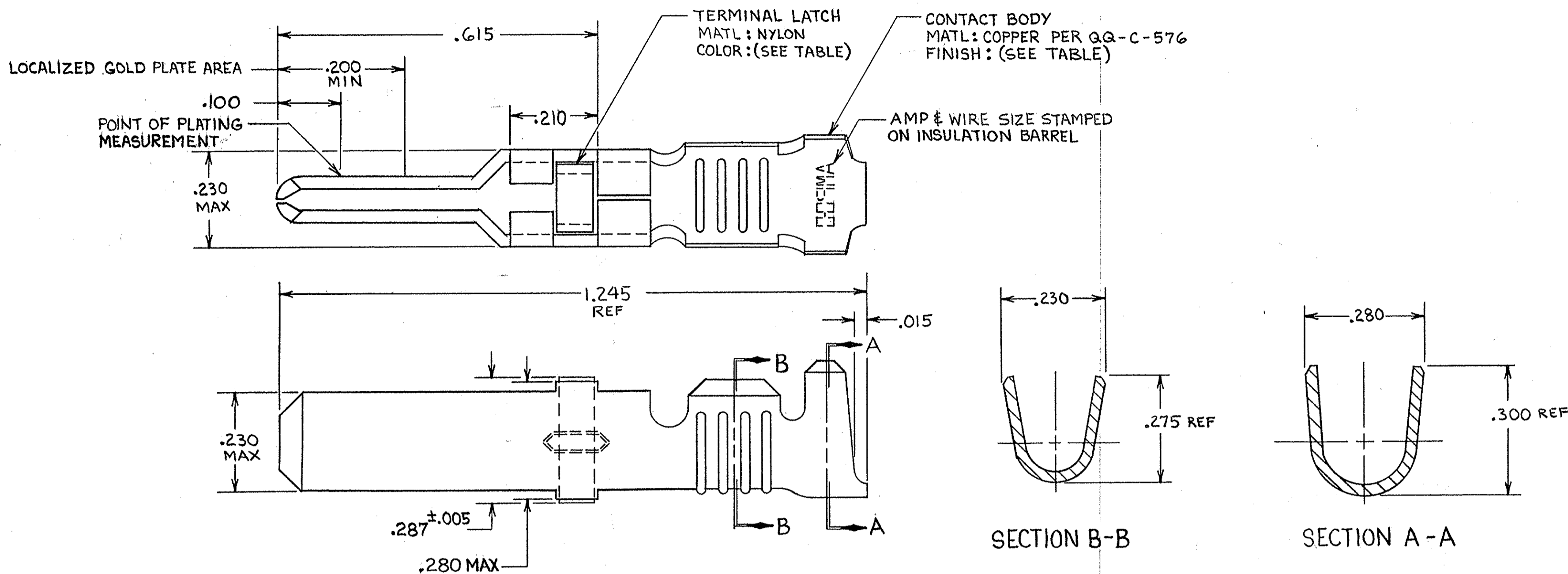

- 1. REELED FOR USE WITH STANDARD APPLICATORS.
- 2. REELED FOR USE WITH HEAVY DUTY MINI-APPLICATORS.
- 3. PLATED WITH .000100 MIN SILVER PER QQ-S-365.
- 4. PLATED WITH .000015 MIN GOLD PER MIL-G-45204 IN THE LOCALIZED GOLD PLATE AREA, GOLD FLASH ON THE REMAINDER, OVER .000030 MIN NICKEL PER QQ-N-290.
- 5. PLATED WITH .000030 MIN GOLD PER MIL-G-45204 IN THE LOCALIZED GOLD PLATE AREA, GOLD FLASH ON THE REMAINDER, OVER .000030 MIN NICKEL PER QQ-N-290.
- 6. PLATED WITH .000050 MIN 93-7% TIN-LEAD ALLOY OVER .000030 MIN NICKEL PER QQ-N-290.
- 7. WIRE RANGE = 10 AWG.
- 8. INSULATION RANGE = .190 - .220 DIA.
- 9. PLATED TIN (NO LEAD), .000050 MIN THK PER ASTM-B-545 OVER NICKEL .000030 MIN THK PER QQ-N-290.

TERMINAL LATCH COLOR	FINISH	STRIP ASS'Y P/N REF	STRIP ASS'Y P/N REF	LOOSE PIECE P/N ASS'Y
BLACK	1	1-66253-0	66253-9	66259-5
NATURAL	3	66253-8	66253-4	66259-4
BLACK	4	66253-7	66253-1	66259-3
BLACK	5	66253-6	66253-2	66259-2
BLACK	6	66253-5	66253-1	66259-1

UNLESS OTHERWISE SPECIFIED DIMENSIONS ARE IN INCHES. TOLERANCES ON: DECIMALS ±.010 ANGLES ±.010		CONTRACT NO		TE Connectivity NAME MALE TYPE XII CONTACT LOOSE PIECE ASS'Y	
MATERIAL SEE CALLOUT		DR <i>Rick Rolabaugh</i> 9-27-85			
FINISH SEE DASH NO		CHK <i>Larry G. Lawver</i> 10-1-85			
		APPD <i>B.S. Bolash</i> 10-1-85			
		APPD <i>Lewis E. Smith</i> 10-3-85		DRAWING NO 66259	
		DSGN APPD		SIZE C	
		OTHER APPD		FSCM NO 00779	
				SCALE NTS	
				SHEET	

66259