

1

2

3

SUB ASSEMBLY PART NO. AND CH. CODE	NO.	PART NO. AND CH. CODE	△ PART NAME	MATERIAL	COLOR	QTY.
7283-8850-30, D	①	7183-8850-30	HOUSING	PBT	BLACK	1
	②	△7158-5597	FRONT HOLDER	PBT	NATURAL	1
	③	7137-2812-80	PACKING	SILICONE RUBBER	BROWN	1

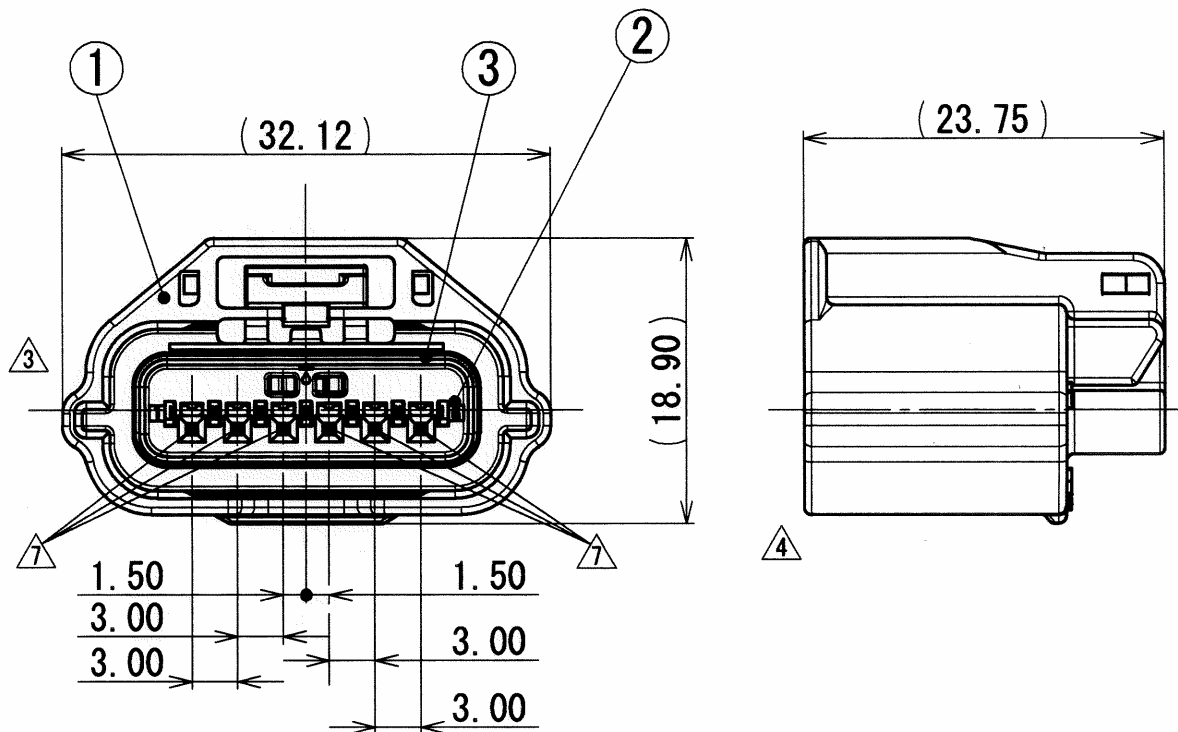
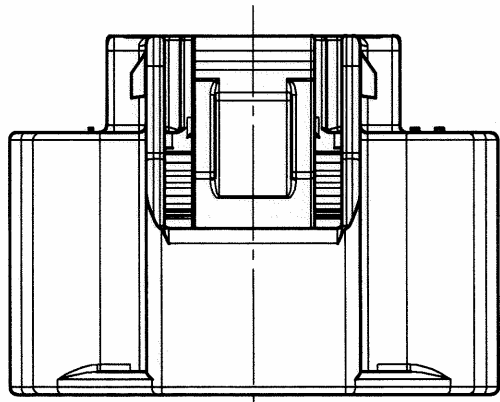

NOTES

- 1. MATING PART NO. : 7282-8850-30
- 2. APPLICABLE TERMINAL NO. : 7116-4415-02 ETC.
- △ 3. APPLICABLE SEAL RUBBER NO. : 7158-3165-90 ETC.
- 4. APPLICABLE UNUSED CAVITY PLUG : 7158-3169-40

注記

- 1. 嵌合相手品番 : 7282-8850-30
- 2. 適用端子品番 : 7116-4415-02 ETC.
- △ 3. 適用ゴム栓品番 : 7158-3165-90 ETC.
- 4. 適用防水栓品番 : 7158-3169-40

△	DATE	REVISION RECORD	NO.	CHKD
7	06/12/19	CHANGED FORM, ETC., D	C06-ZD62	Y. I
6	05/01/07	CHANGED FORM	C04-ZF71	T. Y
5	04/06/30	CHANGED CODE, C	C04-Z677	T. Y
4	03/08/07	CHANGED CODE, B	C03-X324	T. Y
3	02/05/17	CHANGED FORM, A	C02-X538	T. Y
2	01/12/27	CHANGED FORM	C01-Y399	T. Y
1	01/10/23	CHANGED FORM	C01-Y091	T. Y
	01/09/04	NEW	C01-X869	T. Y

GENERAL TOLERANCE								
	10MAX	50MAX	100MAX	250MAX	2500VR	ANGLE	ECCENT	
A	±0.15	±0.2	±0.3	±0.5	±0.75	±30'	0.1	
B	±0.2	±0.3	±0.55	±0.95	±1.4	±30'	0.1	
Ⓒ	±0.3	±0.5	±0.8	±1.4	±2	±30'	0.15	
SPECIFIED							MASS	g

CUSTOMER	CUSTOMER PART NO.	CUSTOMER DWG NO.
OFFICE	TRIAL PART NO.	
VENDOR	VENDOR NO.	
DWG TYPE	DWG SOURCE	DWG DATE
R	NEW	01/09/04
APPROVED	CHECKED	CHECKED
小園	—	岩塚
06.12.20		06.12.20
UNIT	SCL	ANGLE
mm	2:1	3
DESIGN	DRAWN	
M. KASHIYAMA	S. SANTOS	

MATL. SPEC.	SEE TABLE	TREAT. & FIN.
NAME	RH TYPE CONNECTOR 6P	
	SUB ASSEMBLY FEMALE	
PART NO. CH. CODE	7283-8850-30, D	
DWG NO.	7283-8850-30:R	SET DWG NO.
YAZAKI CORPORATION		

1

2

3