

THIS DRAWING IS UNPUBLISHED. RELEASED FOR PUBLICATION  
 © COPYRIGHT - BY TYCO ELECTRONICS CORPORATION. ALL RIGHTS RESERVED.

LOC	DIST	REVISIONS					
GP	00	P	LTR	DESCRIPTION	DATE	DWN	APVD
			0	RELEASED AS PER EC OS13-0226-05	09AUG05	BL	JG

- ① ZINC PLATED .000200-.000400 THICK, YELLOW CHROMATE COATING.
- ② ZINC PLATED .000200-.000400 THICK, CLEAR CHROMATIC COATING.
- ③ UNDERCUT MAY OR MAY NOT BE PRESENT IN THIS AREA.

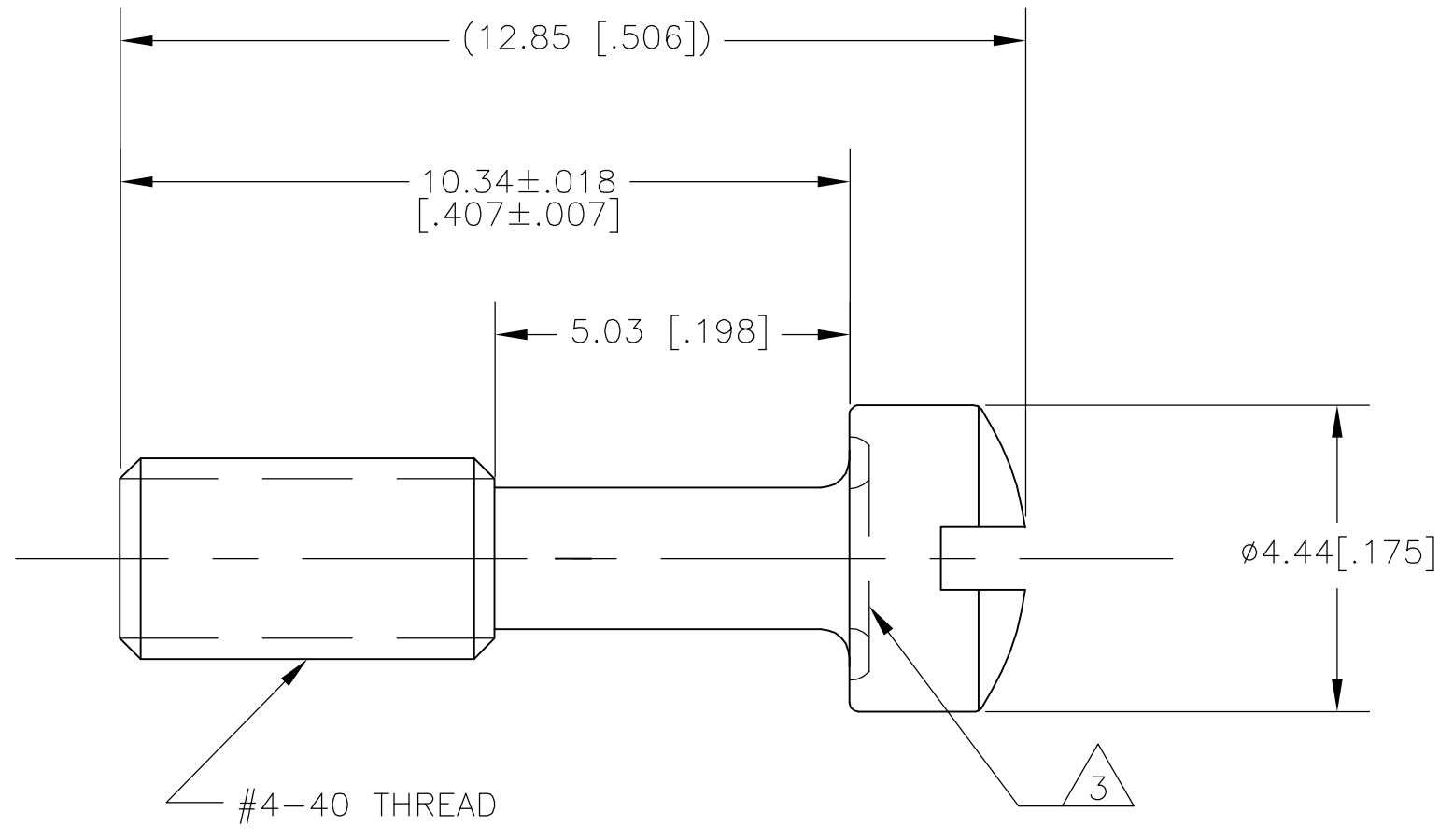

②	5747971-3
①	5747971-2
FINISH	PART NUMBER

THIS DRAWING IS A CONTROLLED DOCUMENT.		DWN	B. LATTUCA	09AUG05	Tyco Electronics Corporation Harrisburg, Pa 17105-3608		
DIMENSIONS: MM [INCHES]		CHK	C. ROHDE	09AUG05			
TOLERANCES UNLESS OTHERWISE SPECIFIED:		APVD	M. WALMSLEY	09AUG05	MOUNTING SCREW, #4-40, AMPLIMITE		
0 PLC ± - 1 PLC ± - 2 PLC ± - 3 PLC ± .005 4 PLC ± - ANGLES ± 1°		PRODUCT SPEC		APPLICATION SPEC			RESTRICTED TO
MATERIAL		WEIGHT		SIZE	CAGE CODE	DRAWING NO	
CARBON STEEL		-		A3	00779	C=5747971	
FINISH		SEE TABLE		CUSTOMER DRAWING			SCALE 10:1
				SHEET 1 OF 1			REV 0

