

## Technical Data Sheet

**Rosenberger**

4.3-10

Adaptor  
Jack - Jack

64K101-K00B1 / PLU010697

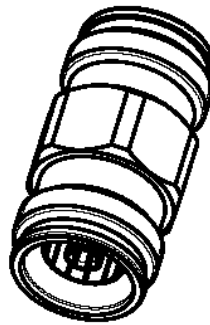
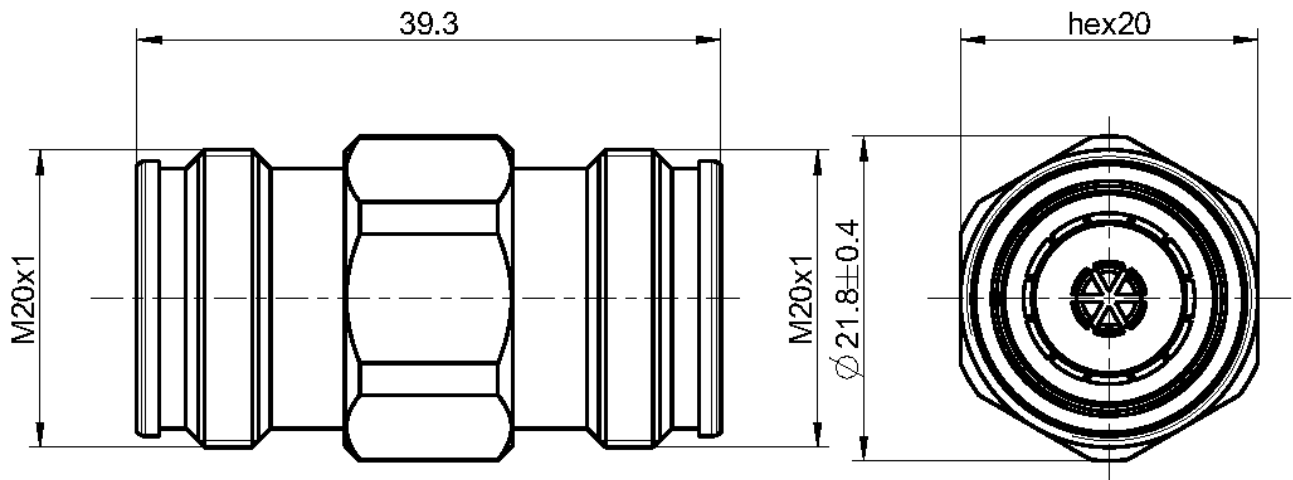

All dimensions are in mm; tolerances according to ISO 2768 m-H

**Interface**

According to IEC 61169-54

**Documents**

N/A

**Material and Plating****Connector parts**

Center contact  
Outer contact  
Body  
Dielectric

**Material**

CuBe  
Brass  
Brass  
PTFE

**Plating**

Silver, 3-6  $\mu\text{m}$   
Silver, 3-6  $\mu\text{m}$   
Flash white bronze over silver(e.g. Optargen®)

# Technical Data Sheet

# Rosenberger

4.3-10

**Adaptor  
Jack - Jack**
**64K101-K00B1 / PLU010697**

## Electrical Data

Impedance	50 Ω
Frequency	DC to 12 GHz
Return loss	≥ 40 dB @ DC to 2 GHz ≥ 34 dB @ 2 GHz to 4 GHz ≥ 28 dB @ 4 GHz to 6 GHz
Insertion loss	≤ 0.05 x √ f [GHz] dB
Electrical delay	95 ps
Insulation resistance	≥ 5 GΩ
Center contact resistance	≤ 1.0 mΩ
Outer contact resistance	≤ 1.0 mΩ
Test voltage	2500 V rms
Working voltage	500 V rms
RF-leakage	≥ 110 dB @ DC to 6 GHz for tool tightened plugs ≥ 90 dB @ DC to 3 GHz for tool-less plugs ≥ 70 dB @ DC 3 to 6 GHz for tool-less plugs
Power handling (at 90 °C, altitude 3000m)	500 W @ 2.0 GHz
Intermodulation (3 <sup>rd</sup> order)	≥ 160 dBc (2 x 46 dBm) @ 0.4 – 4.0 GHz ≥ 166 dBc (2 x 43 dBm) @ 0.4 – 4.0 GHz

## Mechanical Data

Mating cycles	≥ 100
Center contact captivation: axial	> 30 N
Center contact retention force	1.5 - 20 N
Outer contact retention force	4 - 35 N
Engagement force	typ. 100 N
Disengagement force	typ. 80 N
Recommended torque	5 Nm

## Environmental Data

Temperature range	-55 °C to +90 °C operating temperature
Thermal shock	IEC 61169-1 9.4.4
Corrosion resistance	ISO 21207 method B
Vibration	IEC 61169-1 9.3.3 and IEC 60068-2-64
Shock	IEC 61169-1 9.3.14
Degree of protection (mated pair)	IEC 60529, IP68 1h / 25m
RoHS	compliant

## Tooling

N/A

## Suitable Cables

N/A

## Weight

Weight 51.3 g/pce

While the information has been carefully compiled to the best of our knowledge, nothing is intended as representation or warranty on our part and no statement herein shall be construed as recommendation to infringe existing patents. In the effort to improve our products, we reserve the right to make changes judged to be necessary.

Draft	Date	Approved	Date	Rev.	Engineering change number	Name	Date
F. Schmidhammer	05.11.13	F. Fraunhofer	26.10.15	a00	15-s383	S. Huber-Siegl	26.10.15
Rosenberger Hochfrequenztechnik GmbH & Co. KG P.O.Box 1260 D-84526 Tittmoning Germany <a href="http://www.rosenberger.de">www.rosenberger.de</a>						Tel. : +49 8684 18-0 Fax : +49 8684 18-499 Email : <a href="mailto:info@rosenberger.de">info@rosenberger.de</a>	
						Page 2 / 2	