

Montagecode
C04XX
assembly code

Assembly Instruction Montageanweisung

Montagecode
C04XX
assembly code

Abisoliermaße *stripping instruction*

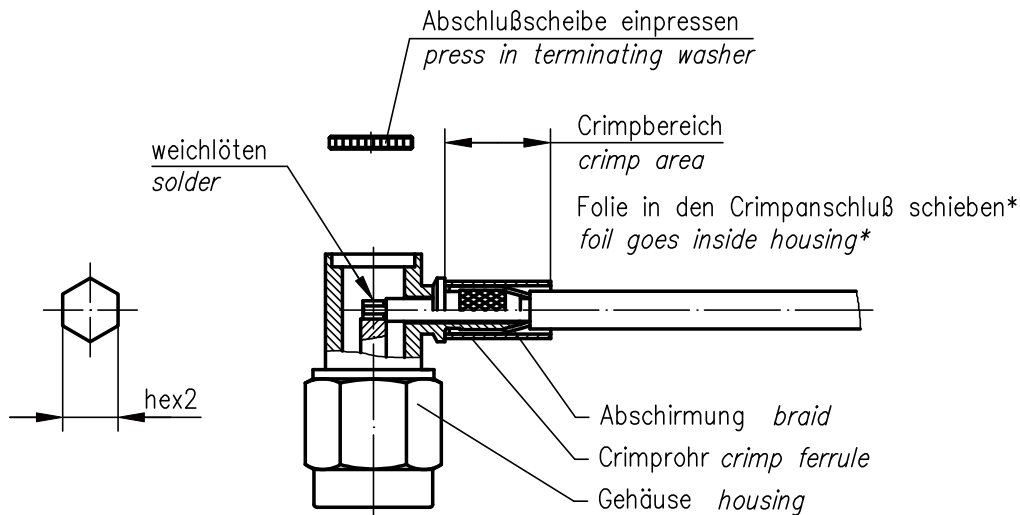
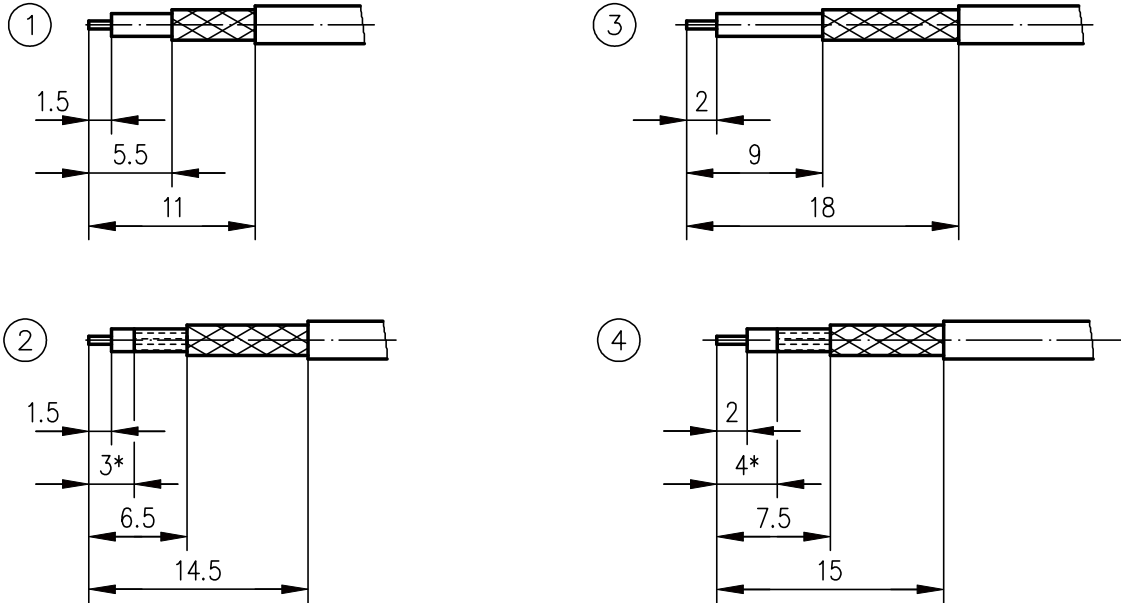

* nur für Kabel mit Folie / only for cables with foil

| XX | Crimpeinsatz <i>crimp insert</i> | 6kt.1 x Länge <i>hex1 x length</i> | 6kt.2 x Länge <i>hex2 x length</i> | Abisoliermaße <i>stripping instruction</i> |
|----|-------------------------------------|---------------------------------------|---------------------------------------|---|
| 03 | N01001A0009 | | 3.25x8 | ① |
| 05 | N01001A0005 | | 5.41x8 | ② |
| 08 | N01001J1274 | | 8.23x8 | ③ |
| 13 | N01001A0010 | | 2.67x8 | ① |
| 14 | N01001A0014 | | 3.65x8 | ① |
| 31 | N01001A0056 | | 6.48x8 | ④ |

| | | | |
|-----------------------|---------------------------------|----------------------|---------------------|
| i | 20993 | 01.07.09 | KL |
| h | 17233 | 25.11.05 | JA |
| g | 12656 | 06.07.01 | MA |
| f | 10832 | 15.09.99 | GJ |
| Index <i>index</i> | Änderung <i>modification</i> | Datum <i>date</i> | Name <i>name</i> |

| | | |
|-----------------------|----------------------|---------------------|
| | Datum <i>date</i> | Name <i>name</i> |
| Gez. <i>drawn</i> | 05.07.94 | PU |
| Gepr. <i>app'd</i> | 05.07.94 | BB |

Series SMA crimp
Serie SMA crimp

Unterl.-
Art **R** TG-Nr.
T00100C0400



Original **A4** Blatt **1/1**

Maßstab
scale **2:1**

Ersatz für/replacement for