

Montagecode
A29XX
assembly code

Assembly Instruction

Montageanweisung

Montagecode
A29XX
assembly code

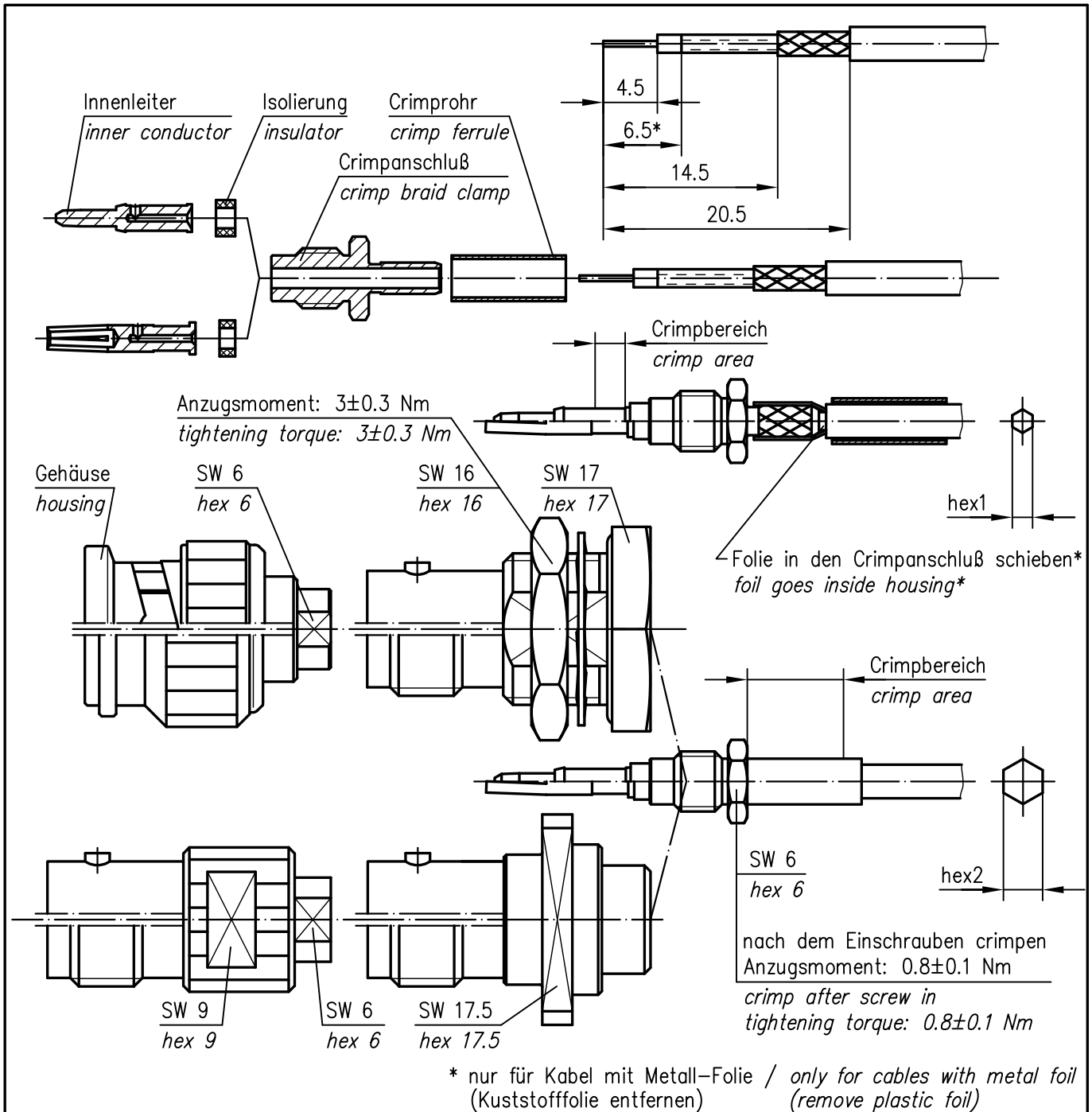

XX	Crimpeinsatz crimp insert	6kt.1 x Länge hex1 x length	6kt.2 x Länge hex2 x length
03	N01003A0009	1.69x2.5	3.25x8
04	N01003L1274	1.69x2.5	4.52x8
13	N01003A0010	1.69x2.5	2.67x8
14	N01003A0014	1.69x2.5	3.65x8

e	23387	24.11.11	MA
d	15207	05.02.04	BJ
c	12656	06.07.01	MA
b	7329	19.11.96	BE
Index index	Änderung modification	Datum date	Name name

	Datum date	Name name
Gez. drawn	18.09.96	Beyer
Gepr. app'd	23.09.96	PU

Series BNC/TNC crimp/crimp
Serie BNC/TNC crimp/crimp

Untert.-
Art **R** TG-Nr.
PLU010473

Ersatz für/replacement for
www.pewtronic.cz



Telegärtner

Original
original **A4** Blatt
sheet **1/1**

Maßstab
scale **2:1**