

Montagecode  
**C37XX**  
assembly code

# Assembly Instruction Montageanweisung

Montagecode  
**C37XX**  
assembly code

Abisoliermaße *stripping instruction*

①

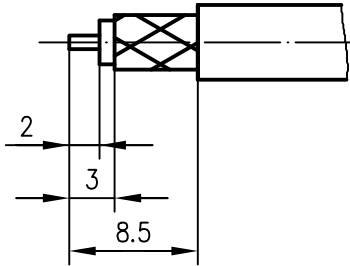

②

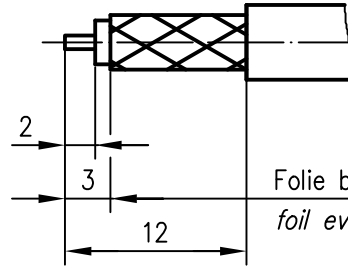

Folie bündig mit Geflecht \*  
foil even with braid \*

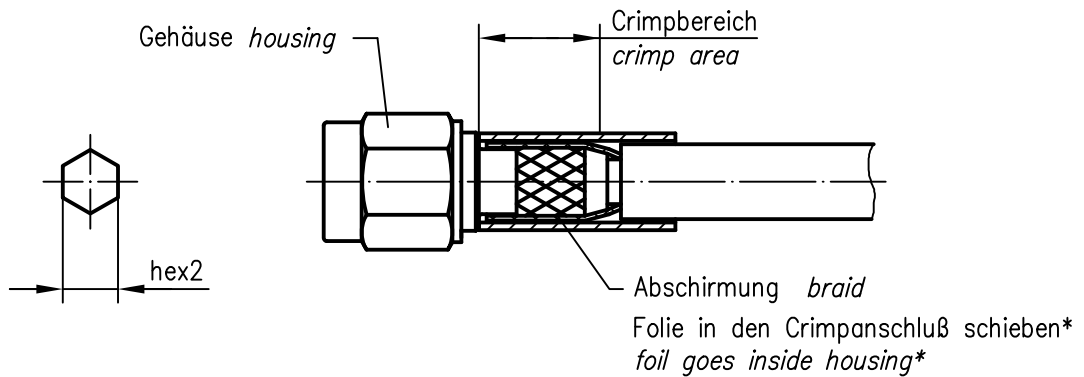
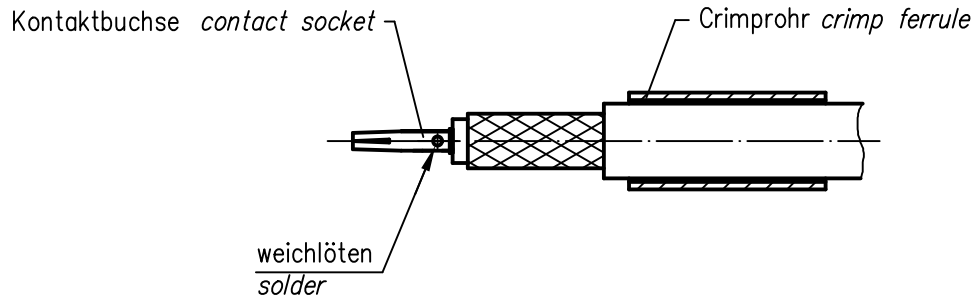

\* nur für Kabel mit Folie / only for cables with foil

XX	Crimpeinsatz <i>crimp insert</i>	6kt.1 x Länge <i>hex1 x length</i>	6kt.2 x Länge <i>hex2 x length</i>	Abisoliermaße <i>stripping instruction</i>	
03	N01001A0009		3.25x8	①	
05	N01001A0005		5.41x8	②	

b	16179	13.12.04	BJ
a	15338	18.03.04	BJ
Index <i>index</i>	Änderung <i>modification</i>	Datum <i>date</i>	Name <i>name</i>

	Datum <i>date</i>	Name <i>name</i>
Gez. <i>drawn</i>	31.01.03	HR
Gepr. <i>app'd</i>	31.01.03	BJ

**Series SMA Reverse crimp**  
**Serie SMA Reverse crimp**

Untert.-  
Art **R** TG-Nr.  
**PLU010153**



Original  
*original* **A4** Blatt  
*sheet* **1/1**

Maßstab  
*scale* **2:1**

Ersatz für/  
*replacement for*