

Montagecode
B33XX
assembly code

Assembly Instruction Montageanweisung

Montagecode
B33XX
assembly code

Abisoliermaße *stripping instruction*

①

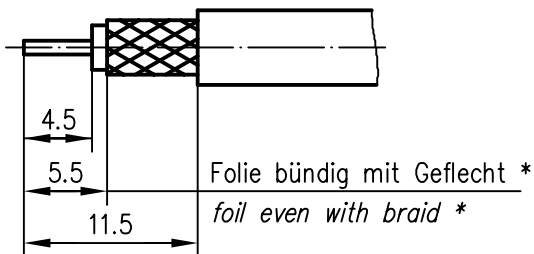

②

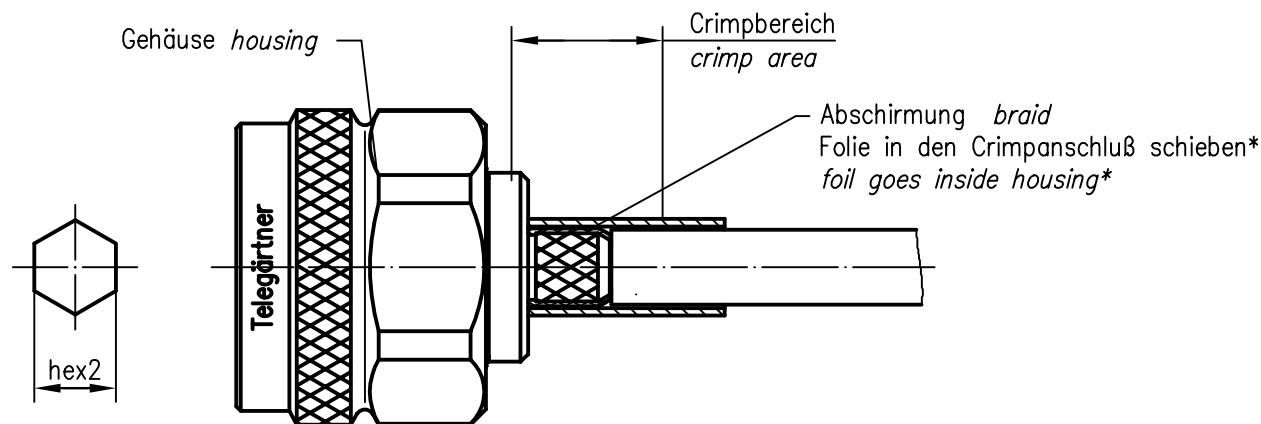
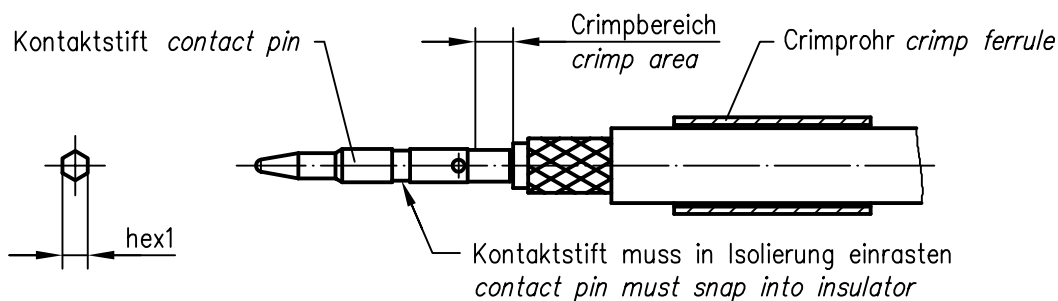
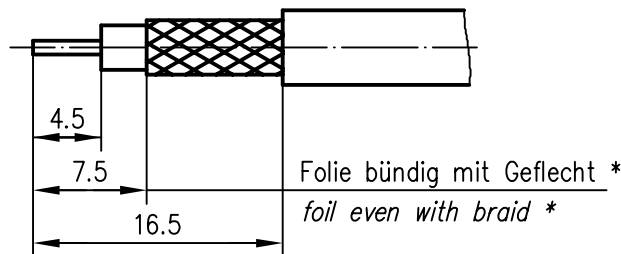

* nur für Kabel mit Folie / only for cables with foil

XX	Crimpeinsatz <i>crimp insert</i>	6kt.1 x Länge <i>hex1 x length</i>	6kt.2 x Länge <i>hex2 x length</i>	Abisoliermaße <i>stripping instruction</i>	
05	N01001A0005	1.69x2.5	5.41x8	①	
31	N01001A0056	1.69x2.5	6.48x8	②	

b	17233	25.11.05	JA
a	12656	13.07.01	MA
Index <i>index</i>	Änderung <i>modification</i>	Datum <i>date</i>	Name <i>name</i>

	Datum <i>date</i>	Name <i>name</i>
Gez. <i>drawn</i>	29.09.00	HM
Gepr. <i>app'd</i>	11.10.00	GJ

**Series N crimp
Serie N crimp**

Untert. Art	TG-Nr.
R	



Original <i>original</i>	A4	Blatt <i>sheet</i>	1/1
-----------------------------	----	-----------------------	-----

Maßstab <i>scale</i>	2:1
-------------------------	-----

Ersatz für/replacement for
PLU010076