

REV	DESCRIPTION	DRAWN	DATE

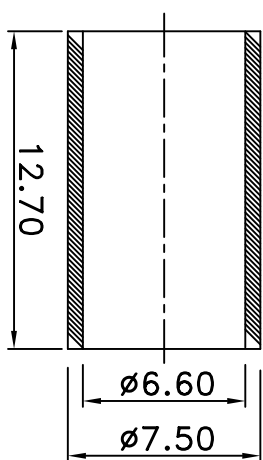
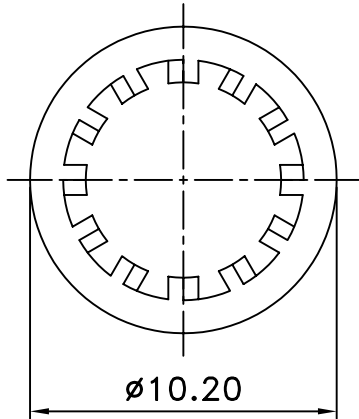
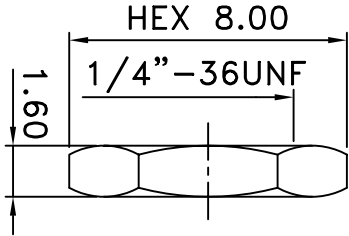
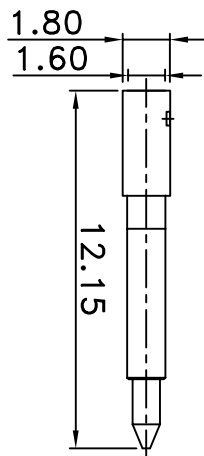
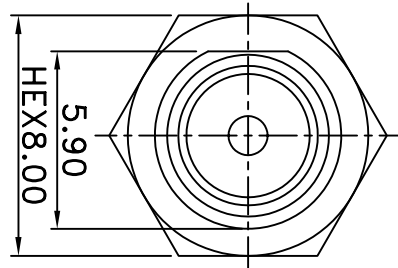
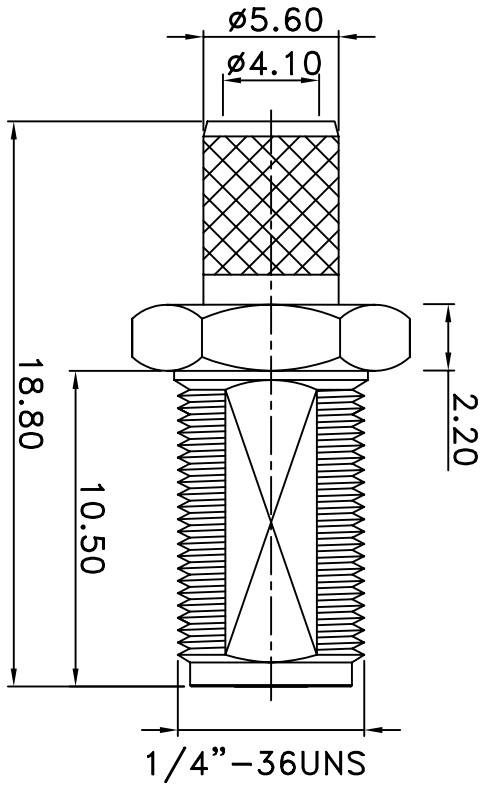

NO	Description	Qty	Material	Finish
7	FERRULE	1	BRASS	GOLD
6	PIN	1	BRASS	GOLD
5	BODY	1	BRASS	GOLD
4	INSULATOR A	1	TEFLON	NONE
3	WASHER	1	BRASS	GOLD
2	WASHER	1	BRASS	GOLD
1	NUT	1	BRASS	GOLD

UNLESS OTHERWISE SPECIFIED
 1.REMOVE ALL BURRS.
 2.BREAK ALL CORNERS & EDGES CO.15 MAX.
 3.CHAMFER 1ST & LAST 30°.
 4.DIAMETERS ON COMMON CENTERS.
 5.ALL DIMENSIONS ARE AFTER PLATING.

* MAJOR DIMENSION
 UNLESS OTHERWISE NOTED TOLERANCES
 0.5-6=±0.2
 6-30=±0.4
 30-120=±0.6
 120-315=±1.0
 ANGLES=±1°

APPROVED
 CHECKED
 DRAWN
 andrew

TITLE
 SMA FEMALE RP BKD CRIMP FOR H155
 DRAWING NO.
 REV A