

REV	DESCRIPTION	DRAWN	DATE

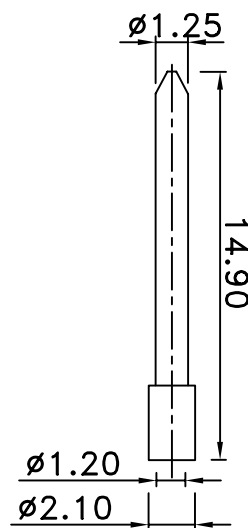
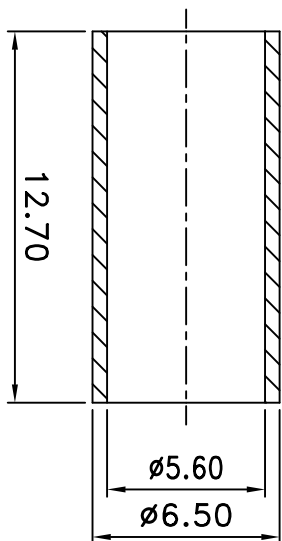
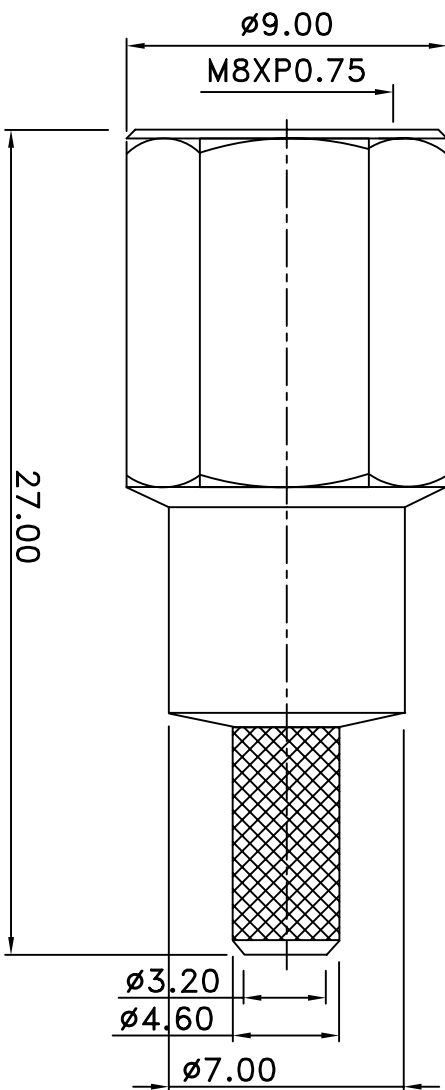

NO	Description	Qty	Material	Finish	UNLESS OTHERWISE SPECIFIED	* MAJOR DIMENSION	APPROVED	TITLE
4	Ferrule	1	Brass	Nickel	1.REMOVE ALL BURRS 2.BREAK ALL CORNERS & EDGES CO.15 MAX. 3.CHAMFER 1ST & LAST THREADS 45. 4.DIAMETERS ON COMMON CENTERS 5.ALL DIMENSIONS ARE AFTER PLATING.	UNLESS OTHERWISE NOTED TOLERANCES 0.5-6= ± 0.2 6-30= ± 0.4 30-120= ± 0.6 120-315= ± 1.0 ANGLES= $\pm 1^\circ$	CHECKED	FME MALE CRIMP FOR RG58
3	Dielectric	1	Delrin	None			DRAWN	DRAWING NO.
2	Pin	1	Brass	Gold			andrew	FILE NO.
1	Body	1	Brass	Nickel				REV A