

REV	DESCRIPTION	DRAWN	DATE

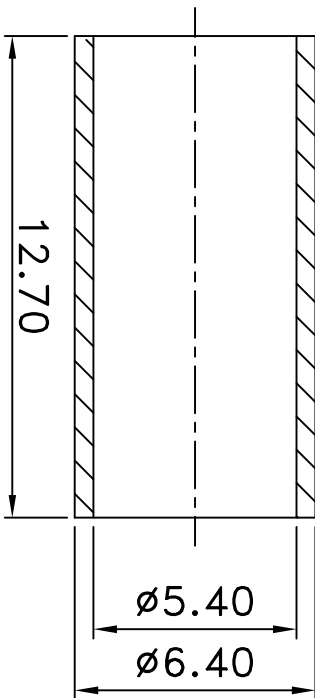
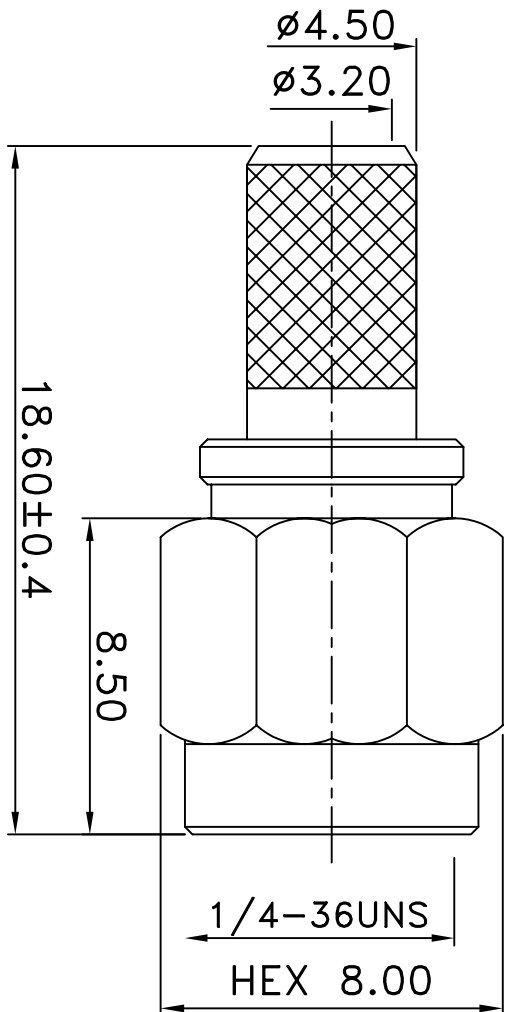
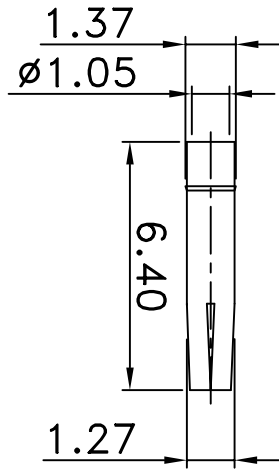

NO	Description	Qty	Material	Finish
7	FERRULE	1	BRASS	GOLD
6	PIN	1	Be Cu	GOLD
5	BODY	1	BRASS	GOLD
4	INSULATOR	1	TEFLON	NONE
3	WASHER	1	STELL	NONE
2	GASKET	1	SILICONE	NONE
1	SHELL	1	BRASS	GOLD

UNLESS OTHERWISE SPECIFIED
 1. REMOVE ALL BURRS.
 2. BREAK ALL CORNERS & EDGES CO.15 MAX.
 3. CHAMFER 1ST & LAST THREADS 45°.
 4. DIAMETERS ON COMMON CENTERS.
 5. ALL DIMENSIONS ARE AFTER PLATING.

* MAJOR DIMENSION
 UNLESS OTHERWISE NOTED TOLERANCES
 0.5-6 = ± 0.2
 6-30 = ± 0.4
 30-120 = ± 0.6
 120-315 = ± 1.0
 ANGLES = $\pm 1^\circ$

APPROVED
 CHECKED
 DRAWN
 SCALE 5/1 UNIT MM DRAWN DATE 03/07/15

TITLE
 SMA MALE RP CRIMP FOR RG58
 DRAWING NO.
 REV A
 FILE NO.